

PRODUCT SUMMARY

SKY19003-001: 0.6 to 3.0 GHz Dual SPST (2xSPST) Shunt Switch (Two-Bit Control) in a WLCSP Package

Applications

- Antenna aperture tuning and dynamic matching for cellular handsets, tablets, and data cards

Features

- Broadband frequency range: 0.6 to 3.0 GHz
- Two RF shunts to ground:
 - Low RON: 4.3 Ω
 - Low COFF: 170 fF
- RF voltage handling in the OFF state: 80 V peak
- High linearity for carrier aggregation applications
- Supply voltage: 2.4 to 4.8 V
- Control line voltage: 1.3 to 3.0 V (control voltage high)
- Low current consumption: 40 μA typical
- Ultra-small WLCSP (8-bump, 1.277 x 1.377 x 0.4 mm typical, 217 μm diameter, 400 μm pitch) package (MSL1, 260 °C per JEDEC J-STD-020)



Skyworks Green™ products are compliant with all applicable legislation and are halogen-free. For additional information, refer to *Skyworks Definition of Green™*, document number SQ04-0074.

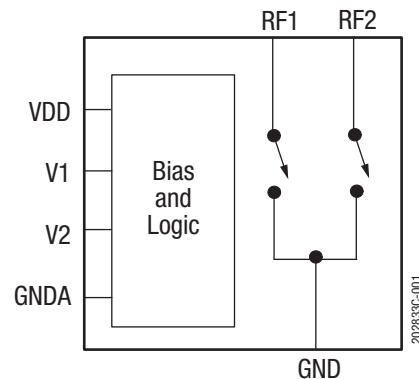

Figure 1. SKY19003-001 Block Diagram

Description

The SKY19003-001 is a wafer level chip scale package (WLCSP) dual-shunt, single-pole, single-throw (2xSPST) switch with integrated logic and bias block. Both paths are connected on one side to a single RF ground bump.

The SKY19003-001 linearity is high enough to meet carrier aggregation requirements. The part is designed to sustain a peak voltage of 80 V typical without going to breakdown.

The logic block operates with a 1.8 V high control voltage and requires a 2.85 V nominal VDD supply.

The SKY19003-001 is provided in a compact 8-bump, 1.277 x 1.377 x 0.4 mm WLCSP that meets requirements for board-level assembly. Bump diameters are 217 microns, with a minimum bump pitch of 400 microns.

A functional block diagram is shown in Figure 1.

Ordering Information

Model Name	Manufacturing Part Number	Evaluation Board Part Number
SKY19003-001: Dual SPST Switch	SKY19003-001	SKY19003-001-EVB

Copyright © 2016 Skyworks Solutions, Inc. All Rights Reserved.

Information in this document is provided in connection with Skyworks Solutions, Inc. ("Skyworks") products or services. These materials, including the information contained herein, are provided by Skyworks as a service to its customers and may be used for informational purposes only by the customer. Skyworks assumes no responsibility for errors or omissions in these materials or the information contained herein. Skyworks may change its documentation, products, services, specifications or product descriptions at any time, without notice. Skyworks makes no commitment to update the materials or information and shall have no responsibility whatsoever for conflicts, incompatibilities, or other difficulties arising from any future changes.

No license, whether express, implied, by estoppel or otherwise, is granted to any intellectual property rights by this document. Skyworks assumes no liability for any materials, products or information provided hereunder, including the sale, distribution, reproduction or use of Skyworks products, information or materials, except as may be provided in Skyworks Terms and Conditions of Sale.

THE MATERIALS, PRODUCTS AND INFORMATION ARE PROVIDED "AS IS" WITHOUT WARRANTY OF ANY KIND, WHETHER EXPRESS, IMPLIED, STATUTORY, OR OTHERWISE, INCLUDING FITNESS FOR A PARTICULAR PURPOSE OR USE, MERCHANTABILITY, PERFORMANCE, QUALITY OR NON-INFRINGEMENT OF ANY INTELLECTUAL PROPERTY RIGHT; ALL SUCH WARRANTIES ARE HEREBY EXPRESSLY DISCLAIMED. SKYWORKS DOES NOT WARRANT THE ACCURACY OR COMPLETENESS OF THE INFORMATION, TEXT, GRAPHICS OR OTHER ITEMS CONTAINED WITHIN THESE MATERIALS. SKYWORKS SHALL NOT BE LIABLE FOR ANY DAMAGES, INCLUDING BUT NOT LIMITED TO ANY SPECIAL, INDIRECT, INCIDENTAL, STATUTORY, OR CONSEQUENTIAL DAMAGES, INCLUDING WITHOUT LIMITATION, LOST REVENUES OR LOST PROFITS THAT MAY RESULT FROM THE USE OF THE MATERIALS OR INFORMATION, WHETHER OR NOT THE RECIPIENT OF MATERIALS HAS BEEN ADVISED OF THE POSSIBILITY OF SUCH DAMAGE.

Skyworks products are not intended for use in medical, lifesaving or life-sustaining applications, or other equipment in which the failure of the Skyworks products could lead to personal injury, death, physical or environmental damage. Skyworks customers using or selling Skyworks products for use in such applications do so at their own risk and agree to fully indemnify Skyworks for any damages resulting from such improper use or sale.

Customers are responsible for their products and applications using Skyworks products, which may deviate from published specifications as a result of design defects, errors, or operation of products outside of published parameters or design specifications. Customers should include design and operating safeguards to minimize these and other risks. Skyworks assumes no liability for applications assistance, customer product design, or damage to any equipment resulting from the use of Skyworks products outside of stated published specifications or parameters.

Skyworks and the Skyworks symbol are trademarks or registered trademarks of Skyworks Solutions, Inc., in the United States and other countries. Third-party brands and names are for identification purposes only, and are the property of their respective owners. Additional information, including relevant terms and conditions, posted at www.skyworksinc.com, are incorporated by reference.